

9.2 R1 Rotating Nut



• Application:

Semi-conductor industries, Robots, Wood machines, Laser cutting machines, Transporting equipment.

• Features:

1. Compact and high positioning:

It is a compact design using nut and support bearing as an integral unit. 45-degree steel ball contact angle make a better axial load. Zero backlash and higher stiffness construction give a high positioning.

2. Simple installation:

It is installed simply by fixing the nut on the housing with bolts.

3. Rapid feed:

No inertial effect produced by the integral unit rotating and the shaft fixed. Can select smaller power to meet the rapid feed requirement.

4. Stiffness:

Have a higher trust and moment stiffness, because the integral unit have an angular contact construction. There is no backlash while rolling.

5. Quietness:

Special end cap design allows steel balls circulating inside the nut. Noise generated by high speed operation lower than ordinary ballscrew.

• Specification:

Example: 2R40-40S2-DFSHR1-800-1000-0.018

↓
HIWIN R1 code

R1 ROTATING NUT

China Patent No. 422327
Germany Patent No. 10108647.4
Taiwan Patent No.166845
U.S.A. Patent No. 6406188B1

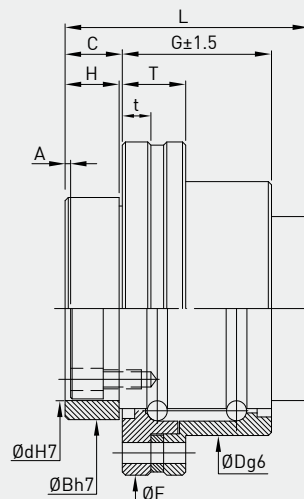
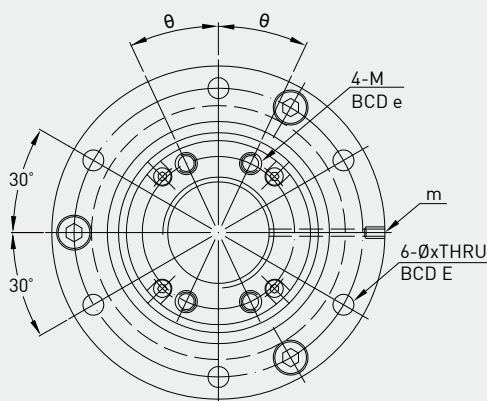

Model	Bearing		Nut				Flange			Bolt				Bush				Oil hole	
	Dynamic Load(kgf)	Static Load(kgf)	D	G	L	C	F	T	t	BCD-E	BCD-e	θ	M	X	d	B	H		A
16-16S2	1299	1826	52	25	44	11.4	68	13	6	60	26	20	M4x0.7P	4.5	33	40	11	2	M4x0.7P
20-20S2	1762	2531	62	30	50	12	78	13	6	70	31	20	M5x0.8P	4.5	39	50	11	2	M4x0.7P
25-25S2	1946	3036	72	37	63	16.5	92	13	6	81	38	20	M6x1P	5.5	47	58	15.5	3	M4x0.7P
32-32S2	3150	5035	80	47	80	21	105	20	9	91	48	25	M6x1P	6.6	58	66	20	3	M6x0.75P
40-40S2	4800	8148	110	62	98	22.5	140	20	9	123	61	25	M8x1.25P	9	73	90	21.5	3	M6x0.75P